



Series V4

Users Manual



**General Purpose
1/4 DIN Temperature Controller**

CE 98

**TOTAL
CUSTOMER
SATISFACTION**



Watlow Controls

1241 Bundy Blvd., P.O. Box 5580, Winona, Minnesota USA 55987-5580
Phone: (507) 454-5300, Fax: (507) 452-4507, <http://www.watlow.com>

December 1998
(1464)

Overview

The V4 1/4 DIN panel mount controller is a general purpose industrial PID temperature controller. The V4 provides a reliable cost-effective solution for most temperature control applications. Thermocouple, RTD, and Current and Voltage sensors are supported. Dual outputs can be configured to support heating and cooling. The secondary output can also be configured as an alarm.

V4 features include: a NEMA 4X front panel seal, a 3-year warranty, meets European CE requirements and has a 4 inch deep case with removable connectors for wiring convenience.

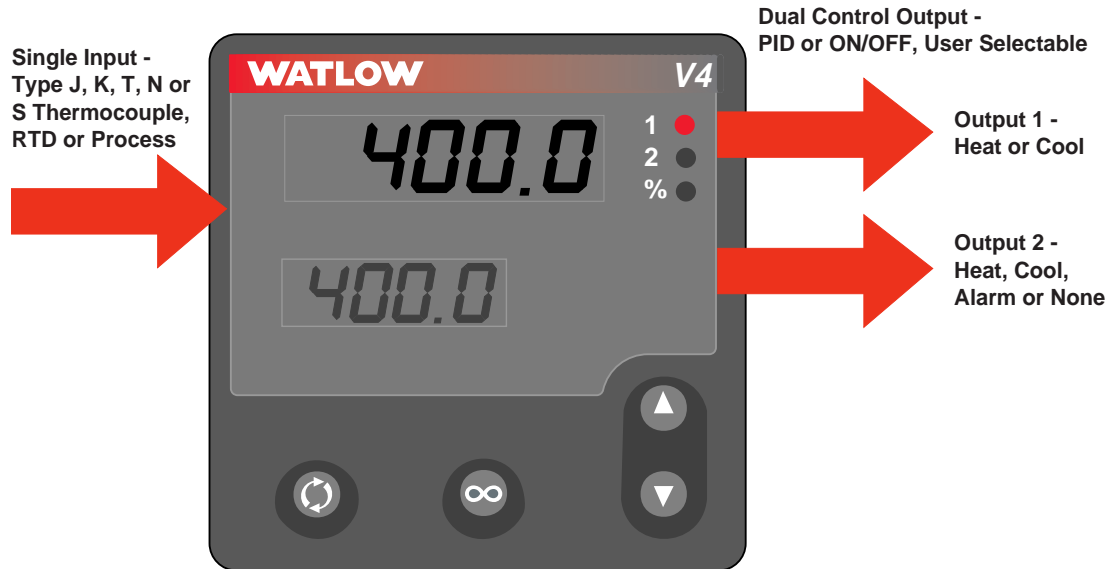

Figure 2a — Series V4 inputs and outputs.

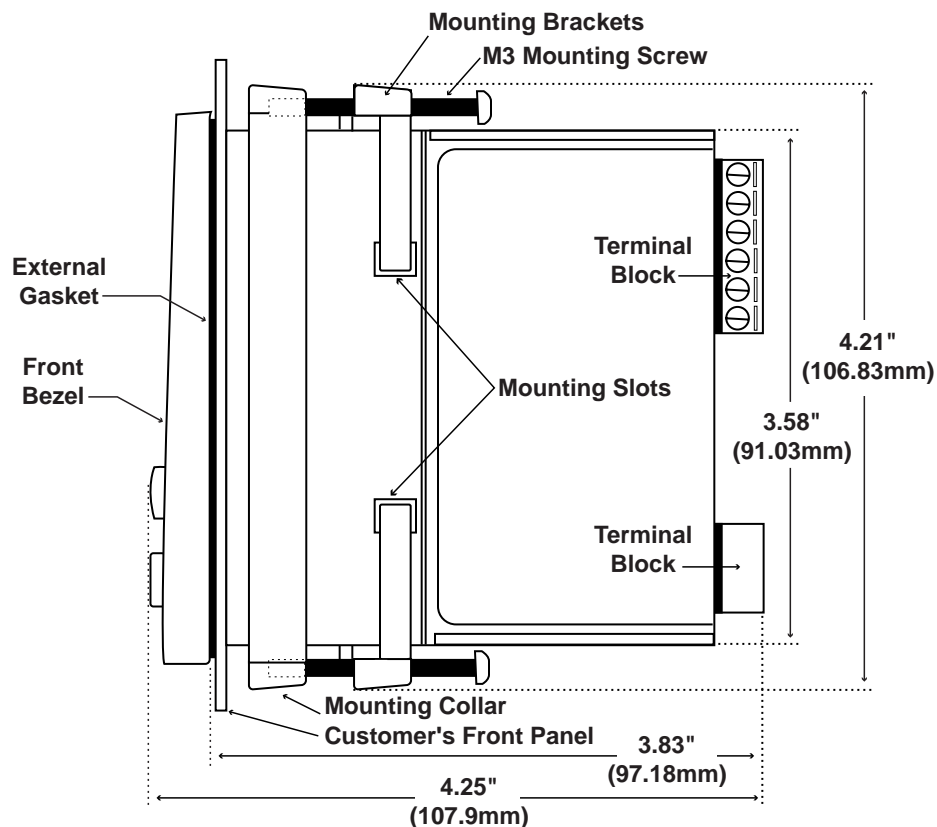

Figure 2b - Controller dimensions.

Keys and Displays

Upper Display: Indicates the process value, actual temperature, operating parameter values or an open sensor. When powering up, the Process display will be blank for five seconds.

- To set to blank, set `dSP` to `SEE` in the Setup Menu.

Lower Display: Indicates set point, output value, parameters for data in the upper display, or error and alarm codes.

- To set to blank, set `dSP` to `Pro` in the Setup Menu.

Advance Key: Press to advance through the Operations, Setup, and Calibration Menus. In the Auto mode, new data is self-entering in five seconds.



Infinity/Home Key:

- Press once to clear any latched alarms. Also disables deviation alarm output if silencing is enabled.
- Press again within five seconds to change from Auto to Manual or vice versa. While in Manual mode, percent power is in the lower display sensor error.

Output 1 Indicator Light: Lit when Output 1 is energized.

Output 2 Indicator Light: Lit when Output 2 is active. This output can be configured as a control or alarm output.

% Percent Power Indicator Light:

- Lit: the controller is in Manual operation. Press the  Infinity key twice to enter Automatic operation.
- Blinking: press the  Infinity key to toggle between Auto and Manual. Returns to its previous state and stops blinking if the  Infinity key is not pressed within five seconds.

Up-arrow and Down-arrow Keys:

- Increases or decreases the value of the displayed parameter.
- Press lightly to increase or decrease the value by one.
- Press and hold down to increase or decrease the displayed value at a rapid rate. New data will self-enter in five seconds, or can be entered by pressing the Advance Key.
- Press both simultaneously for three seconds to enter the Setup Menu. The `LOC` parameter appears.
- Continue pressing both keys to enter the Calibration Menu.

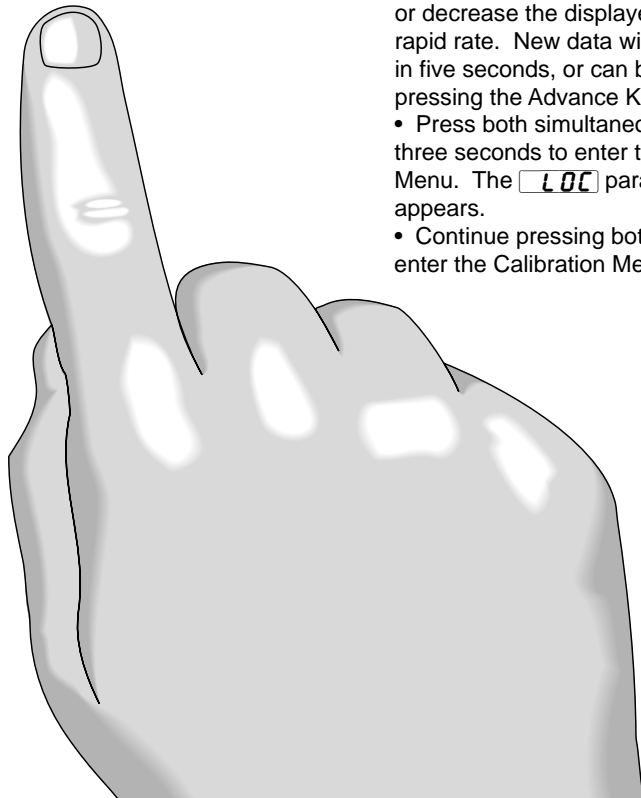

Installation and Removal

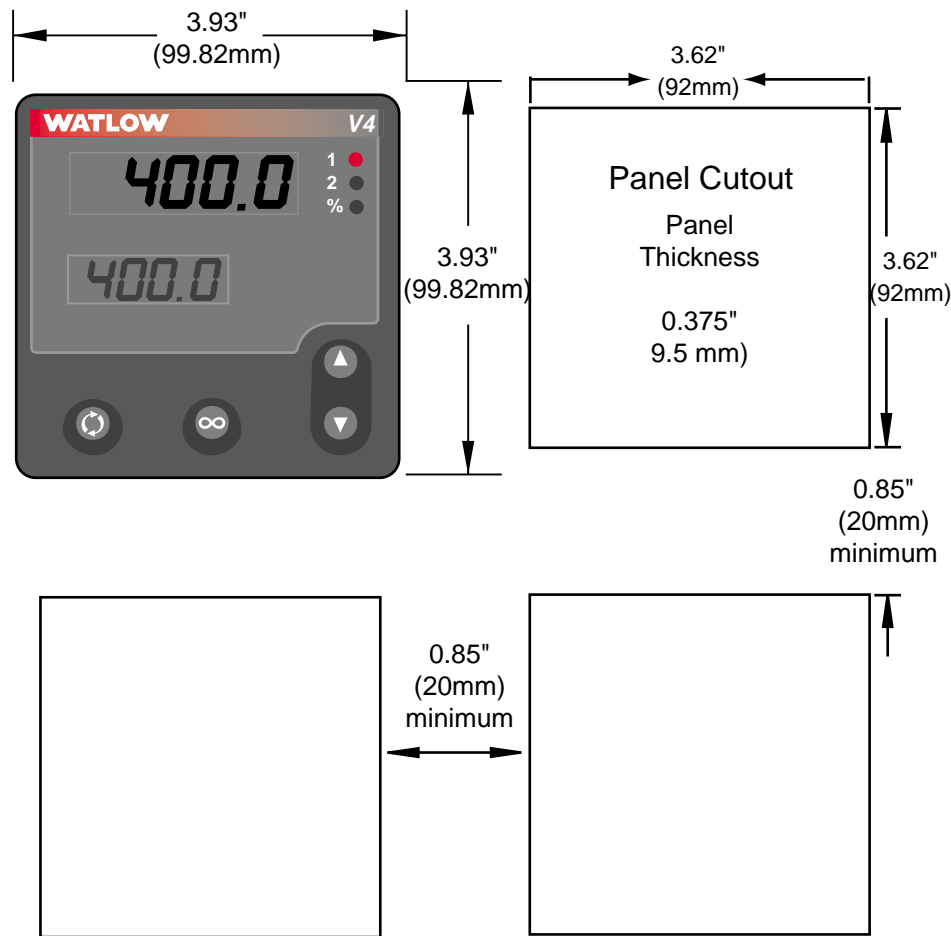

Figure 4 - Series V4 multiple panel cutout dimensions.

NOTE: Measurements between panel cutouts are the minimum recommended.

Installing the Series V4 Controller

Installing and mounting requires access to the back panel.

1. Make the panel cutout using the panel cutout dimensions as shown in Figure 4.
2. Make sure the rounded side of the external case gasket is facing the panel surface.
3. Check to see that the gasket is not twisted, and is seated within the case bezel flush with the panel.
4. Slightly compress the top and bottom side of the V4 Case while pulling the controller into the panel cutout (Figure 5a). Slide the mounting collar over the back of the controller. The tabs on the collar must line up with the mounting ridges on the case for secure installation. The tab holes are facing the back of the controller.
5. Adjust the mounting bracket screws enough to allow for the mounting collar and panel thickness. Snap the upper and lower mounting brackets on the case of the controller (Figure 5 b). Make sure all the grips are well engaged on the mounting slots of the controller. (The four screw heads are facing the back of the controller.)
6. Make sure the case is seated properly. Tighten the installation screws firmly against the mounting collar to secure the unit (Figure 5c). To ensure NEMA4X seal, there should be no space between the bezel and panel. Over tightening the screws will distort the case and make it difficult to remove or replace the controller.

Installation and Removal (continued)

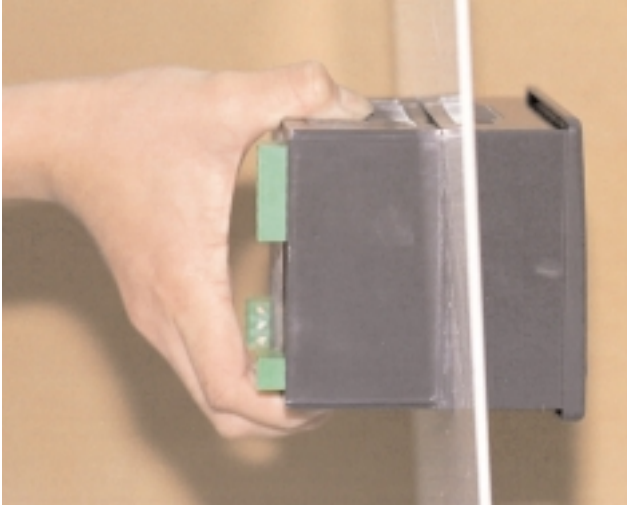

Figure 5a - Slightly compress the case while pulling the controller into the panel cutout.

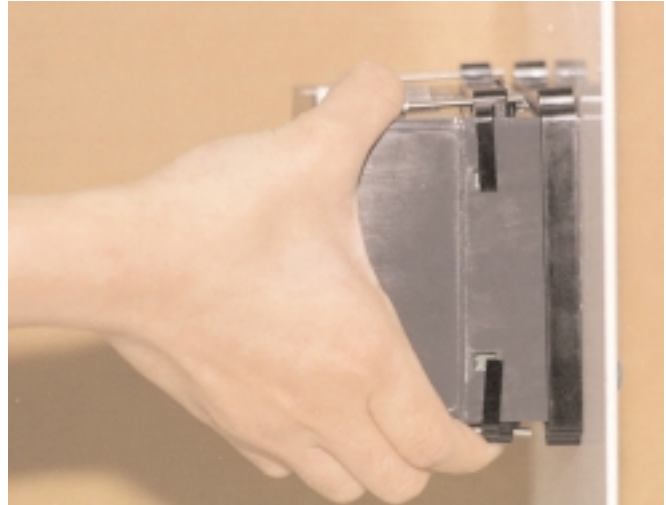

Figure 5b - Snap the top and bottom mounting bracket into the slots.

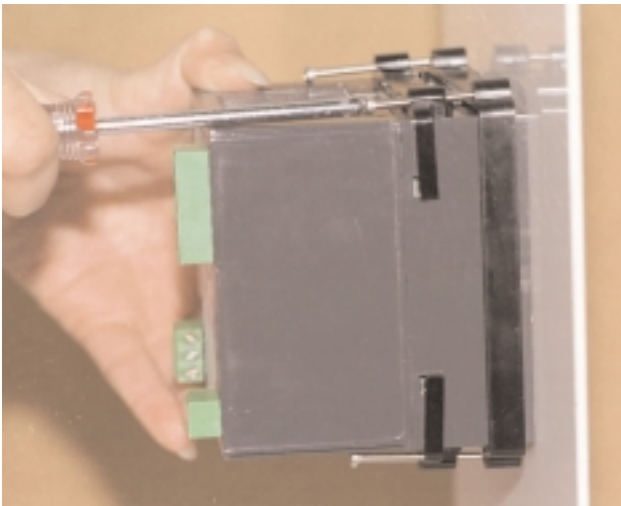

Figure 5c - Tighten screw to secure the controller.

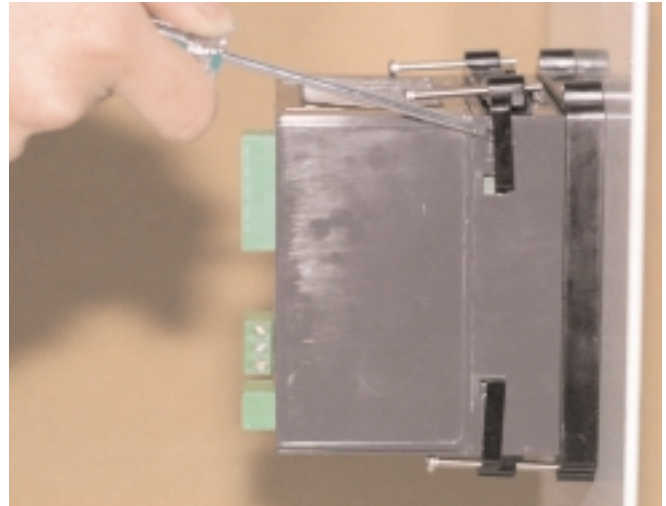

Figure 5d - Remove the controller using a flat screwdriver.

NOTE: Be careful not to over-tighten the screws. This may cause the mounting cover to fail. Over-tightening occurs when the front bezel is touching the customer's front panel.

Removing the Series V4 Controller

1. Loosen the upper and lower mounting bracket screws.
2. Use a flat screw driver to unsnap the four grips on the opposite side of upper and lower mounting brackets. Push the brackets back and forth gently until they can be pulled off easily.
3. Remove controller from the panel.

Wiring the Series V4

Power Wiring

High Voltage

100 to 240V~ (ac), nominal (85 to 264 actual) V4TH - - - - -

Low Voltage

14 to 24V≈ (ac/dc) V4TL - - - - -



WARNING:

To avoid damage to property and equipment and/or injury or loss of life, use National Electric Code (NEC) standard wiring practices to install and operate this unit. Failure to do so could result in injury and/or death, or such damage.

NOTE:

Taking the unit out of the case is not a normal operating condition and should only be done by a qualified maintenance installation technician. Power to the case should be disconnected before removing or installing the controller into its case.

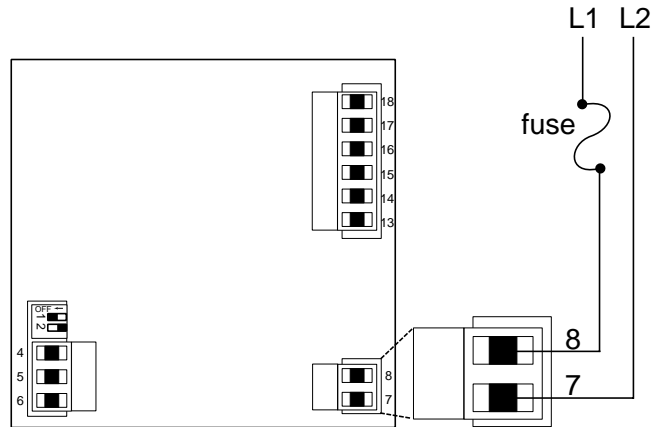

Figure 6 - Power wiring.

Sensor Installation Guidelines

We suggest you mount the sensor at a location in your process or system where it reads an average temperature. Put the sensor as near as possible to the material or space you want to control. Air flow past this sensor should be moderate. The sensor should be thermally insulated from the sensor mounting.



WARNING:

The case terminals may still carry live voltage when the unit is removed.



WARNING:

Irreversible damage will occur if high voltage is applied to the low voltage unit.



WARNING:

To avoid damage to property and equipment and/or injury or loss of life, use National Electric Code (NEC) standard wiring practices to install and operate this unit. Failure to do so could result in injury and/or death, or such damage.

Wiring Example

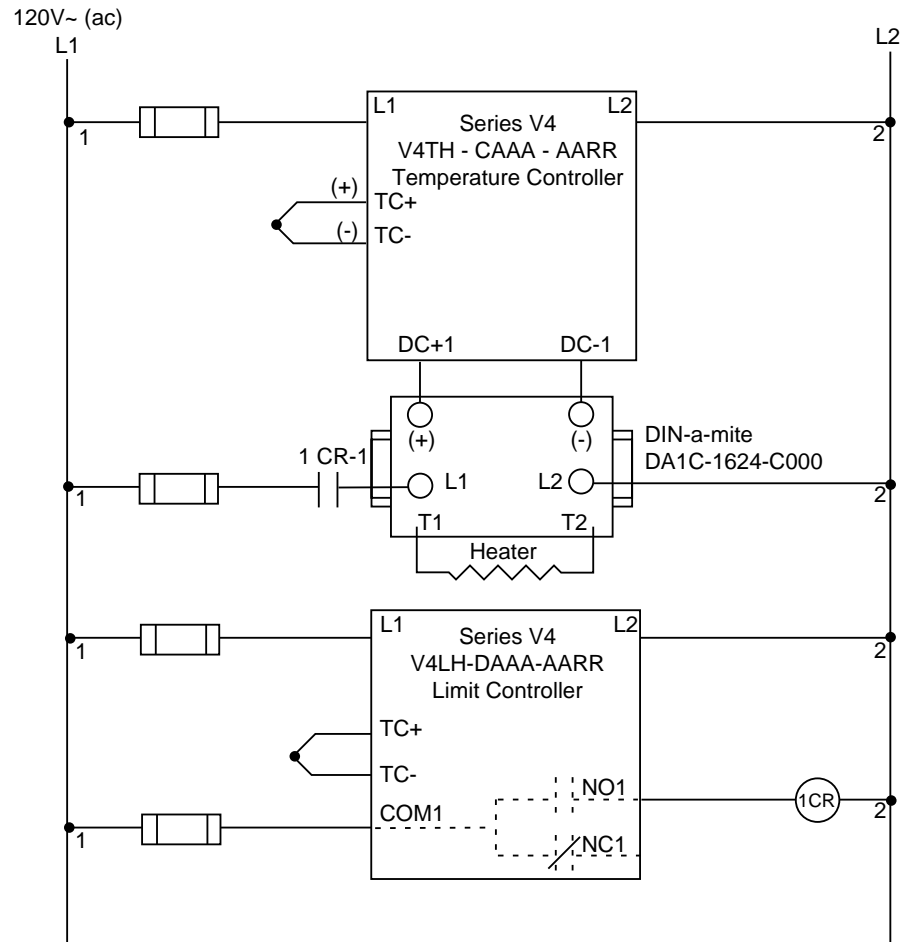
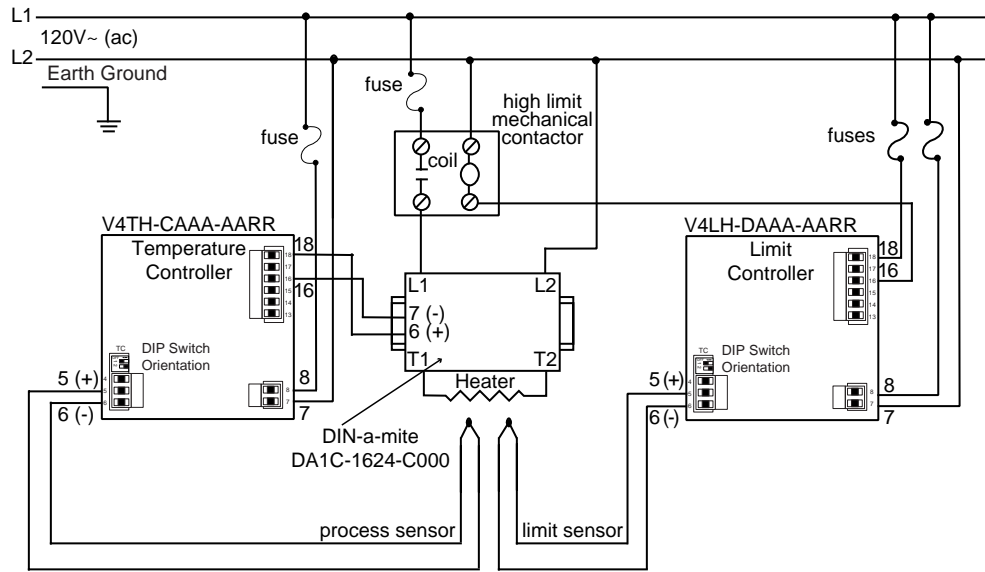

Figure 7 - System wiring example.

NOTE:

Successful installation requires five steps:

- Choose the controller's hardware configuration and model number;
- Choose a sensor;
- Install the controller;
- Wire the controller and
- Configure the controller.

Input Wiring

Figure 8a – Thermocouple

Extension wire for thermocouples must be of the same alloy as the thermocouple itself to limit errors.

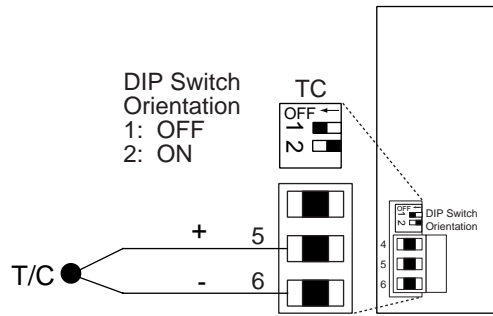

Figure 8b – RTD (2- or 3-Wire) 100Ω Platinum

There could be a +2°F input error for every 1Ω of lead length resistance when using a 2-wire RTD. That resistance, when added to the RTD element resistance, will result in erroneous input to the instrument. To overcome this problem, use a 3-wire RTD sensor, which compensates for lead length resistance. When extension wire is used for a 3-wire RTD, all wires must have the same electrical resistance (i.e. same gauge, same length, multiple-stranded or solid, same metal).



WARNING:

To avoid damage to property and equipment and/or injury or loss of life, use National Electric Code (NEC) standard wiring practices to install and operate this unit. Failure to do so could result in injury and/or death, or such damage.

NOTE: When an external device with a non-isolated circuit common is connected to the 4-20mA or dc output, you must use an isolated or ungrounded thermocouple.

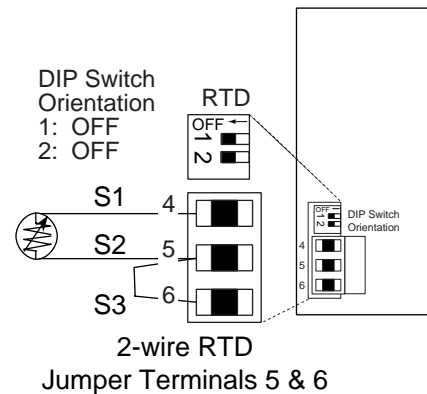
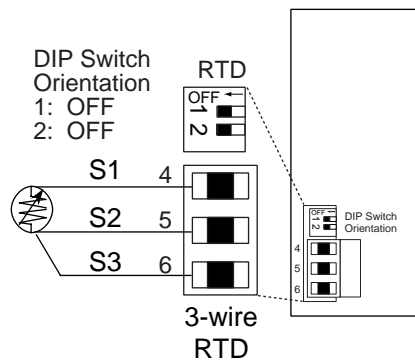

Figure 8c – Process, 4-20mA

Input impedance: 5Ω

Figure 8d – Process, 0-5V_{DC} (dc)

Input impedance: 10kΩ



CAUTION: Process input does not have sensor break protection. Outputs can remain full on.

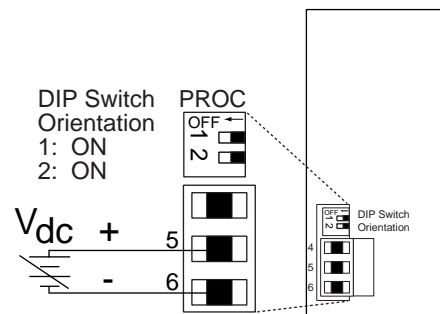
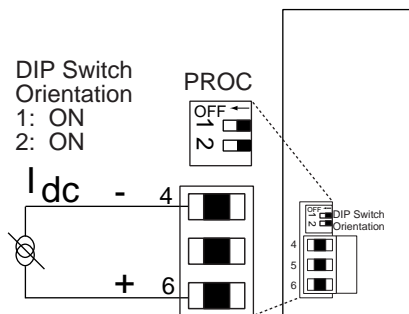



WARNING:

To avoid damage to property and equipment and/or injury or loss of life, use National Electric Code (NEC) standard wiring practices to install and operate this unit. Failure to do so could result in injury and/or death, or such damage.

Output 1 Wiring

Figure 9a – **Mechanical Relay**
Without Contact Suppression

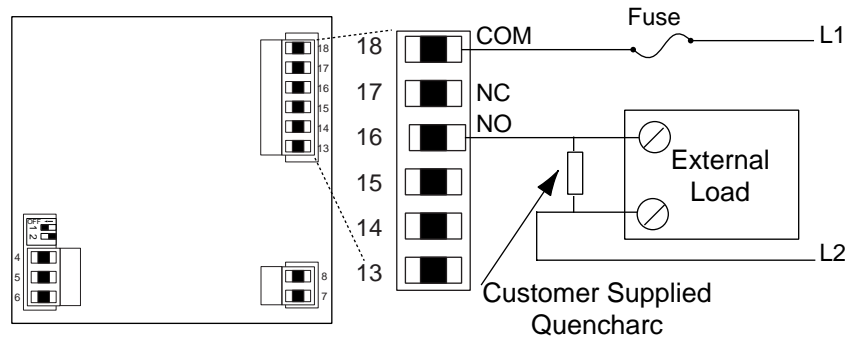

V4T _ - D _ _ _ - _ _ _ _

Form C, rated at 8A @ 125V~ (ac) or 5A @ 240V~ (ac)

Minimum load current: 100mA @ 5V= (dc)

NOTE:

Switching inductive loads (relay coils, solenoids, etc.) with the mechanical relay, switched dc or solid-state relay output options requires use of an R.C. suppressor.

Watlow carries the R.C. suppressor Quencharc brand name, which is a trademark of ITW Pakron. Watlow Part No. 0804-0147-0000.

Figure 9b – **Solid State Relay**
Without Contact Suppression

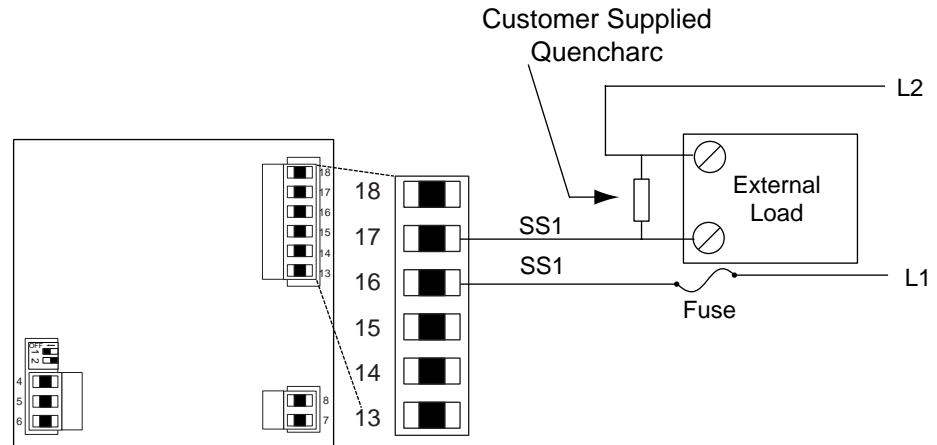

V4T _ - K _ _ _ - _ _ _ _

0.5 amps (AC loads only)

Output 1 Wiring

Figure 10a – **Switched DC, Open Collector**

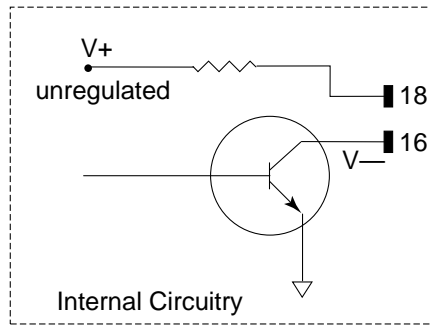
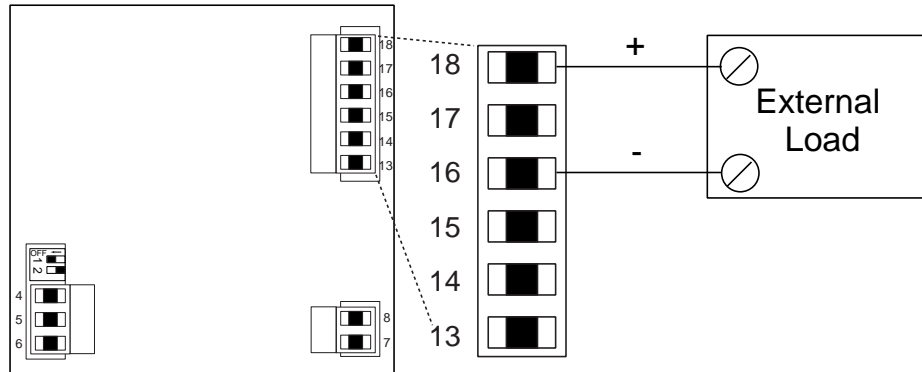

V4T _ - C _ _ _ _ _

NOTE:

When an external device with a non-isolated circuit common is connected to the 4-20mA or dc output, you must use an isolated or ungrounded thermocouple.

Figure 10b – **4-20mA Process**

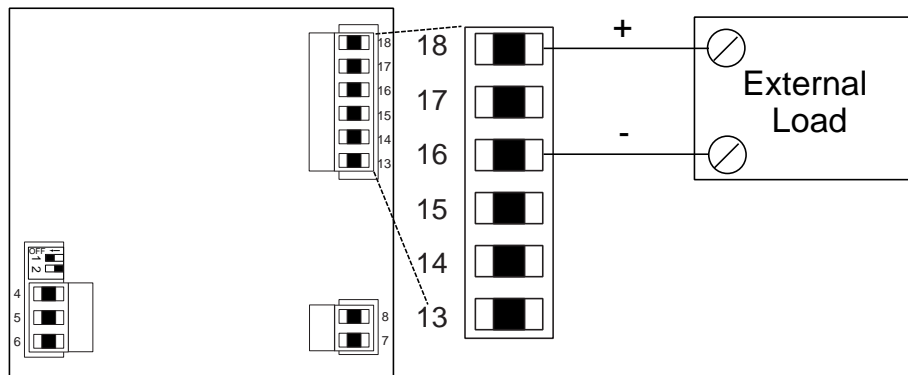

V4T _ - F _ _ _ _ _

Maximum load impedance: 800Ω

Output 2 Wiring

Figure 11a – Mechanical Relay Without Contact Suppression

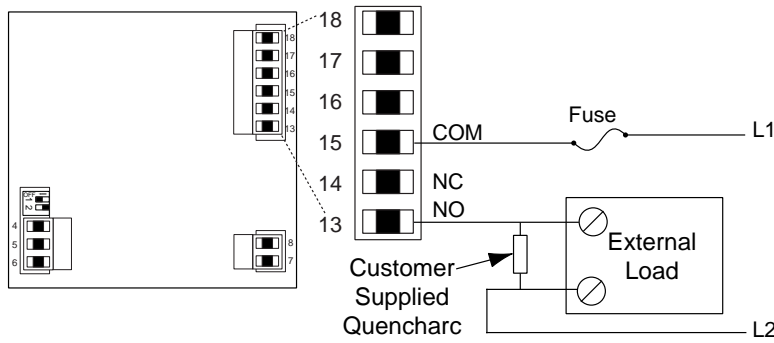

V4T _ _ D _ _ _ _ _

Form C, rated at 8A @ 125V~ (ac) or 5A @ 240V~ (ac). Minimum load current: 100mA @ 5V= (dc)

Figure 11b – Solid State Relay Without Contact Suppression

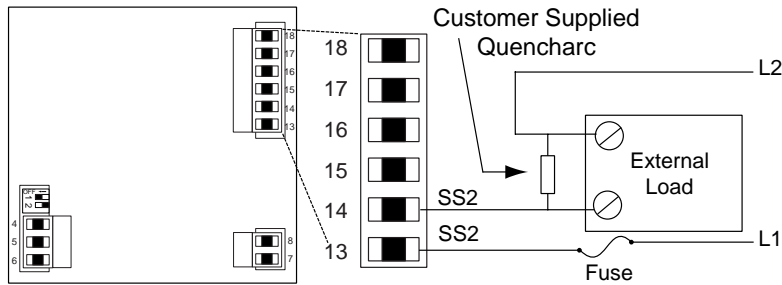

V4T _ _ K _ _ _ _ _

0.5 amps (AC loads only)

Troubleshooting Alarms and Errors

Indication		Probable Cause(s)
Power	<ul style="list-style-type: none"> No power. 	<ul style="list-style-type: none"> Power to unit may be off. Fuse may be blown. Breaker may be tripped. Safety interlock door switch etc. may be activated. Separate system limit control may be latched. Wiring may be open. Input Power may be incorrect.
Alarms	<ul style="list-style-type: none"> Alarm won't occur. 	<ul style="list-style-type: none"> Alarm output may be off. Alarm set points may be incorrect. Alarm may be silenced. Alarm sides may be incorrect. Controller may be in diagnostics mode.
	<ul style="list-style-type: none"> Alarm won't clear. 	<ul style="list-style-type: none"> Alarm may be latched. Alarm set points may be incorrect. Alarm hysteresis may be incorrect. Input may be in error condition.
Error Code Messages	<p>(----) in the upper display indicates a Series V4 error; error code number is visible in bottom display</p> <ul style="list-style-type: none"> (----) (Er2) (----) Er4 (----) Er5 (----) Er6 (----) Er7 	<ul style="list-style-type: none"> Sensor underrange error (applies only to RTD units) Configuration error. Non-volatile checksum error A/D underflow error. A/D overflow error.

Output 2 Wiring

Figure 12a – Switched DC, Open Collector

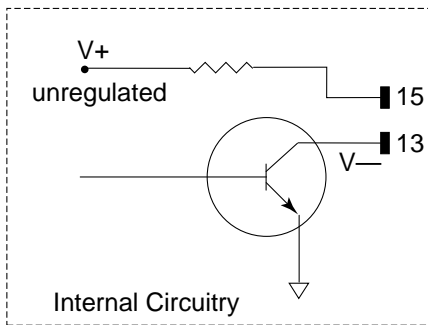
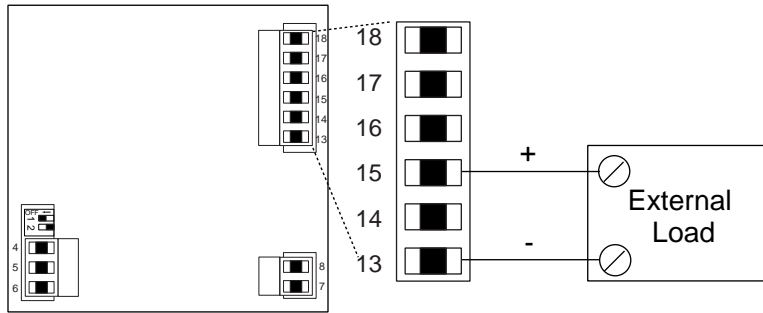

V4T _ _ C _ _ _ _ _

Corrective Action

- Check switches, fuses, breakers, interlocks, limits, connectors, etc. for energized condition and proper connection.

- Measure power upstream for required level. Check part number for input power required.
- Check wire size.
- Check for bad connections.
- Configure output as an alarm.
Check alarm set points..
- To clear the alarm, correct the alarm condition; check to see if the alarm is latched.
- Check the alarm sides setting.
- Check the alarm type setting.
- Check the alarm logic for compatibility with system peripherals and annunciators.
- Check the power limit setting.
- Check the operation mode.
- Check the alarm output function.
- Check the °C or °F setting.
- Check the calibration offset value; set it to a lower level.

- Sensor input generated a value lower than allowable signal range, or A/D circuitry malfunctioned. Enter a valid input. Make sure *ln* parameter (Setup Menu) matches your sensor and DIP switches are set accordingly.
- Microprocessor is faulty; consult factory.
- Unless power interruption occurred while controller was storing data, nonvolatile memory is bad; consult factory.
- A/D circuit is underrange. Check sensor; if functioning properly, consult factory. Make sure *ln* parameter (Setup Menu) matches your sensor and DIP switches are set accordingly.
- A/D circuit is overrange. Check sensor; if functioning properly, consult factory. Make sure *ln* parameter (Setup Menu) matches your sensor and DIP switches are set accordingly.

Calibration

Before attempting to calibrate, make sure you read through the procedures carefully and have the proper equipment called for in each procedure. Make sure the DIP switches are in the proper position for the input type.

Entering the Calibration Menu

In the Calibration Menu, various input signals must be supplied for the controller to go through its auto calibration. The Calibration Menu can only be entered from the Lock parameter in the Setup Menu. Press the / keys simultaneously for 3 seconds (± 1 second). The parameter appears in the lower display with "no" in the upper display.

Figure 13 -
Entering the
Calibration Menu.

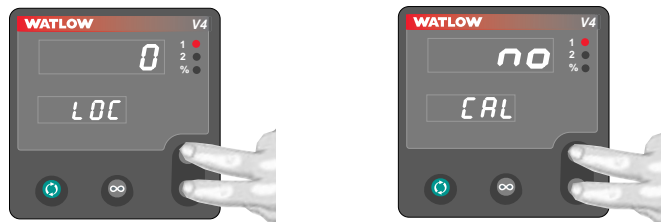

NOTE:
Calibration values will not be retained unless you are in the MANUAL mode. Do not enter the MANUAL mode until you are at the correct input parameters.

NOTE:
While in the Calibration Menu, the controller output(s) go off and the alarm output (if present) is on.

Any inadvertent change in the displayed data, when pressing the / keys, is ignored. Calibration values won't be retained unless you are in the manual mode. Press the or key to change the upper display to Press to enter the calibration sequence.

Upon entering the calibration menu, the upper display window indicates . It continues to indicate (with the exception of calibration of the 4-20mA output) while the operator walks through the entire calibration parameter list. While calibrating the 4-20mA output, the upper display contains a numeric value to be slewed up or down until the output value is correct. The controller uses the lower display to prompt the user as to what the input should be.

With the parameter, select either parameters which include displaying °F, rate, reset, and proportional band in degrees or units. Or select (System International) and the displayed parameters are °C, integral, derivative, and proportional band in % of span.

Once the information has been properly established and maintained for at least 5 to 10 seconds, the key may then be used to display the next prompt. After the final input is established, press the key twice to return the controller to the configuration menu at the top of the parameter list.

Restoring Factory Calibration

The parameter restores the factory calibration values to the Series V4. If you calibrate your control incorrectly, you have the option to default to the original values. Once you leave the menu, the values are entered.

1. Press the / keys simultaneously for three seconds. The LOC parameter appears in the lower display. Continue holding the / keys until the lower display reads .
2. Press the key until appears in the upper display.
3. through the calibration menu until appears in the lower display.
4. Press the key until appears in the upper display.
5. Press the key and the V4 advances to test the displays.

This procedure is used only to restore calibration, it is not meant to clear values.

Calibration Menu

Figure 14 - Calibration Parameters.

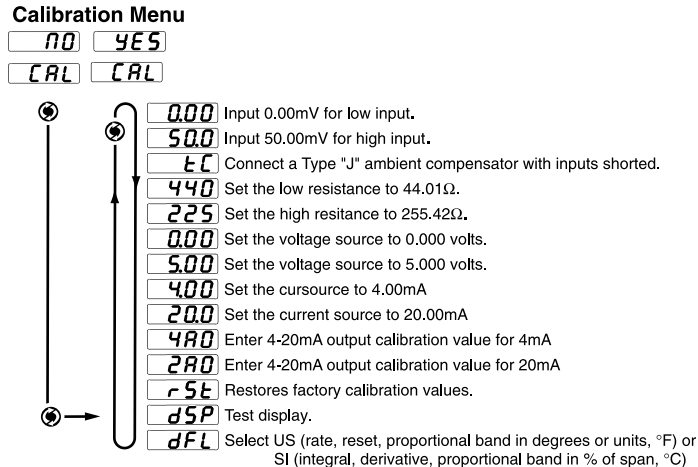

Thermocouple Field Calibration Procedure

Equipment Required

- Type "J" Reference Compensator with reference junction at 32°F/0°C, or Type "J" Thermocouple Calibrator set at 32°F/0°C.
- Precision millivolt source, 0-50mV min. range, 0.01mV resolution

NOTE:

Before calibration on an installed controller, make sure all data and parameters are documented.

Setup And Calibration

1. Connect the ac line voltage L1 and L2 to the proper terminals.
2. Connect the millivolt source to Terminal 6 Negative and Terminal 5 Positive on the Series V4 terminal block. Use regular 20 - 24 gauge wire. Make sure the DIP switch is set for thermocouple input.
3. Apply power to the controller and allow it to warm up for 15 minutes. After warm-up put the controller in the Calibration Menu. Select YES.
4. Press the ∞Infinity key twice to enter the manual mode. The controller is calibrating when % indicator light is on. Make sure the controller is in manual mode only when you are in the correct parameters.
5. At the 0.00 prompt, enter 0.00mV from the millivolt source to the control. Allow at least 10 seconds to stabilize. Press the ⏩Advance key.
6. At the 50.0 prompt, enter 50.00mV from the millivolt source to the Series V4. Allow at least 10 seconds to stabilize. Press the ⏩Advance key.
7. At the prompt, disconnect the millivolt source, and connect the reference compensator or thermocouple calibrator to Terminal 6 Negative, and Terminal 5 Positive on the Series V4 terminal block. If using a compensator, turn on and short the input wires. If using "J" calibrator, set to simulate 32°F/0°C. Allow 10 seconds for the control to stabilize. The controller will leave the CAL mode if one minute passes between key activations. Press the ∞Infinity key twice to exit the manual mode. To conclude the thermocouple calibration, advance the ⏩Advance key to the next prompt or exit the CAL menu.

RTD Field Calibration Procedure

Equipment Required

- 1K Ω precision decade resistance box with 0.01 Ω resolution.

NOTE:

When the % indicator light is on, the controller is automatically calibrating. Your sequence is VERY important. Always move to the next parameter before changing the calibration equipment.

Setup And Calibration

1. Connect the ac line voltage L1 and L2 to the proper terminals.
2. Connect the decade resistance box to Terminal 4, 5 and 6 on the terminal block. Use regular 20 - 24 gauge wire of the same length and type. Make sure the DIP switch is set for RTD input.
3. Apply power to the controller and allow it to warm up for 15 minutes. After warm-up put the controller in the menu. Select . Press the Advance key until the 440 prompt is displayed.
4. Press the Infinity key twice to enter the manual mode. The controller is calibrating when the % indicator light is on. Make sure the controller is in manual mode only when you are in the correct parameters.
5. At the 440 prompt, set the decade resistance box to 44.01. Allow at least 10 seconds to stabilize. Press the Advance key.
6. At the 255 prompt, set the decade resistance box to 255.42. Allow at least 10 seconds to stabilize. Press the Infinity key twice to exit the manual mode. The controller will leave the mode if one minute passes between key activations. To conclude the RTD calibration, press the Advance key to the next prompt or exit the menu.

0-5 Volt Input Field Calibration Procedure

Equipment Required

- Precision dc voltage source 0-5 volt minimum range with 0.001 volt resolution.

NOTE:

Before calibration on an installed controller, make sure all data and parameters are documented.

Setup and Calibration

1. Connect the ac line voltage L1 and L2 to the proper terminals on the V4.
2. Connect the voltage/current source to Terminal 5 (+) and 6 (-) on the Series V4 terminal block. Use regular 20 - 24 gauge wire. Make sure the DIP switch is set for process input.
3. Apply power to the controller and allow it to warm up for 15 minutes. After warm-up put the controller in the menu. See Figure A.3. Select . Press the Advance key until 0.00 is displayed.
4. Press Infinity twice to enter the manual mode. The controller is calibrating when the % indicator light is on. Make sure the controller is in the manual mode only when you are in the correct parameters.
5. At the 0.00 parameter, set the voltage source to 0.000 volts. Allow at least 10 seconds to stabilize. Press the Advance key.
6. At the 5.00 parameter, set the voltage source to 5.000V \approx (dc). Allow at least 10 seconds to stabilize. The controller leaves the mode if 1 minute passes between key activations. Press Infinity twice to exit the manual mode. To conclude the 0-5 volt calibration, press the Advance key to the next prompt or exit the menu.

4-20mA Input Field Calibration Procedure

Equipment Required:

- Precision current source 0-20mA minimum range with 0.01mA resolution.

Setup and Calibration

1. Connect the ac line voltage L1 and L2 to the proper terminals on the V4.
2. Connect the current source to Terminal 4 (-) and 6 (+) on the Series V4 terminal block. Use regular 20 - 24 gauge wire. Make sure the DIP switch is set for process input, see.
3. Apply power to the controller and allow it to warm up for 15 minutes. After warm-up put the controller in the menu. Select YES. Press the **⏩** Advance key until 4 is displayed.
4. Press **∞** Infinity twice to enter the manual mode. The controller is calibrating when the % indicator light is on. Make sure the controller is in the manual mode only when you are in the correct parameters.
5. At the 4.00 parameter, set the current source to 4.00mA. Allow at least 10 seconds to stabilize. Press the **⏩** Advance key.
6. At the 20.0 parameter, set the current source to 20.00mA. Allow at least 10 seconds to stabilize. The controller leaves the mode if 1 minute passes between key activations. Press **∞** Infinity twice to exit the manual mode. To conclude, press the **⏩** Advance key to the next prompt or exit the menu.

NOTE:

When the % indicator light is on, the controller is automatically calibrating. Your sequence is VERY important. Always move to the next parameter before changing the calibration equipment.

4-20mA Output Field Calibration Procedure

Equipment Required:

- 300Ω, 1/2 watt 10% resistor.
- 4 - 1/2 digit Digital Multimeter.

Setup And Calibration

1. Connect the ac line voltage L1 and L2 to the proper terminals of the V4. Set the multimeter to measure current.
2. Connect the multimeter in series with the 300Ω resistor to Terminal 18 Positive and 16 Negative on the Series V4 terminal block. Use regular 20 - 24 gauge wire.
3. Apply power to the controller and allow it to warm up for 15 minutes. After warm-up put the controller in the menu. Select YES. Press the **⏩** Advance key until the 4A0 prompt is displayed.
4. Press the **∞** Infinity key twice to enter the manual mode. The controller is calibrating when the % indicator light is on.
5. At the prompt, the multimeter should read approximately 4mA. Allow at least 10 seconds to stabilize.
6. Use the **⬆** Up-arrow/**⬇** Down-arrow keys (reverse acting) to adjust the reading on the multimeter for 3.85mA ± 0.10mA. Press the **⏩** Advance key.
7. At the prompt, the multimeter should read approximately 20mA. Allow at least 10 seconds to stabilize. The controller will leave the mode if one minute passes between key activations except for 4-20mA units.
8. Use the **⬆** UP/**⬇** DOWN keys (reverse acting) to adjust the reading on the multimeter for 20.15mA ± 0.10mA.
9. To conclude the 4-20mA output calibration, advance the **⏩** Advance key to the next prompt or exit the menu.

NOTE:

Before calibration on an installed controller, make sure all data and parameters are documented.

NOTE:

Details of a “Note” appear here in the narrow margin on the outside of each page.

CAUTION:

Details of a “Caution” appear here in the narrow margin on the outside of each page.

WARNING:

Details of a “Warning” appear here in the narrow margin on the outside of each page.



Quality and Mission Statement:

Watlow Controls will be the world's best supplier of industrial temperature control products, services, and systems by exceeding our customers', employees', and shareholders' expectations.

Safety Information

We use note, caution and warning symbols throughout this book to draw your attention to important operational and safety information.

A “NOTE” marks a short message in the margin to alert you to an important detail.

A “CAUTION” safety alert appears with information that is important for protecting your equipment and performance. Be especially careful to read and follow all cautions that apply to your application.

A “WARNING” safety alert appears with information that is important for protecting you, others and equipment from damage. Pay very close attention to all warnings that apply to your application.

The safety alert symbol, , (an exclamation point in a triangle) precedes a general CAUTION or WARNING statement.

The electrical hazard symbol, , (a lightning bolt in a triangle) precedes an electric shock hazard CAUTION or WARNING safety statement.

Technical Assistance

If you encounter a problem with your Watlow controller, see the Troubleshooting Table and review all of your configuration information to verify that your selections are consistent with your application: inputs; outputs; alarms; limits; etc. If the problem persists after checking the above, you can get technical assistance from your local Watlow representative, or by dialing (507) 454-5300.

An applications engineer will discuss your application with you.

Please have the following information available when calling:

- Complete model number
- All configuration information
- User's Manual
- Diagnostic menu readings

Your Feedback

Your comments or suggestions on this manual are welcome. Please send them to: Technical Writer, Watlow Controls, 1241 Bundy Blvd., P.O. Box 5580, Winona, MN 55987-5580. The Series V4 User's Manual is copyrighted by Watlow Winona, Inc., © July 1998, with all rights reserved.

How to Reach Us

- Phone: (507) 454-5300.
- Fax: (507) 452-4507.
- For technical support, ask for an Applications Engineer.
- To place an order, ask for Customer Service.
- To discuss a custom option, ask for a Series V4 Product Manager.

Warranty

The Watlow Series V4 is warranted to be free of defects in material and workmanship for 36 months after delivery to the first purchaser for use, providing that the units have not been misapplied. Since Watlow has no control over their use, and sometimes misuse, we cannot guarantee against failure. Watlow's obligations hereunder, at Watlow's option, are limited to replacement, repair or refund of purchase price, and parts which upon examination prove to be defective within the warranty period specified. This warranty does not apply to damage resulting from transportation, alteration, misuse, or abuse.

Returns

- Call or fax Customer Service for a Return Material Authorization (RMA) number before returning a controller.
- Put the RMA number on the shipping label, and also on a written description of the problem.
- A restocking charge of 20% of the net price is charged for all standard units returned to stock.

Declaration of Conformity

Series V4



WATLOW SINGAPORE PTE LTD

Asia Controls

55, Ayer Rajah Crescent, #03-23
Ayer Rajah Industrial Estate
Singapore 139949

Declares that the following product:

English

Designation: Series V4
Model Number(s): V4T(H or L)-(C D F or K) (A C D or K) AA-AA (Any two letters or numbers)
Classification: Control, Installation Category II, Pollution Degree II
Rated Voltage: 100 to 240V~ (ac) or 24V≈ (ac/dc)
Rated Frequency: 50/60 Hz.
Rated Power Consumption: 12VA maximum

Meets the essential requirements of the following European Union Directive(s) using the relevant section(s) of the normalized standards and related documents shown:

89/336/EEC Electromagnetic Compatibility Directive

EN 50082-2: 1995 EMC Generic immunity standard, Part 2, Industrial environment
EN 61000-4-2: 1995 Electrostatic discharge
EN 61000-4-4: 1995 Electrical fast transients
ENV 50140: 1994 Radiated immunity
ENV 50141: 1994 Conducted immunity
ENV 50204: 1995 Cellular phone
EN 50081-2: 1994 EMC Generic emission standard, Part 2: Industrial environment
EN 55011: 1991 Limits and methods of measurement of radio disturbance characteristics of industrial, scientific and medical radio-frequency equipment (Class A)
EN 61000-3-2: 1995 Limits for harmonic current emissions
EN 61000-3-2: 1995 Limitations of voltage fluctuations and flicker

72/23/EEC Low-Voltage Directive

EN 61010-1: 1993 Safety requirements for electrical equipment for measurement, control, and laboratory use, Part 1: Generic requirements

WATSON NG SAI HIONG
Name of Authorized Representative

SINGAPORE
Place of issue

General Manager
Title of Authorized Representative

December, 1998
Date of Issue

Signature of Authorized Representative
(1469)

Specifications

(1465)

Control Mode

- Microprocessor-based, user selectable control modes
- Single input, dual output
- 2.5Hz input sampling rate
- 1Hz display update rate
- Ramp to set point: 0 to 9999 degrees or units per hour
- Heat and cool auto-tune operator interface

Operator Interface

- Sealed membrane front panel
- Dual, four-digit red or green displays
- Advance, Up-arrow, Down-arrow, and Infinity keys
- User selectable screen display

Accuracy

- Calibration accuracy and sensor conformity: $\pm 0.1\%$ of span, $\pm 1^\circ\text{C}$ @ $77^\circ\text{F} \pm 5^\circ\text{F}$ ($25^\circ\text{C} \pm 3^\circ\text{C}$) ambient and rated line voltage
- Accuracy span: 1000°F (540°C) minimum
- Temperature stability: $\pm 0.2^\circ\text{F}/^\circ\text{F}$ ($\pm 0.2^\circ\text{C}/^\circ\text{C}$) rise in ambient maximum

Sensors/Inputs

- Thermocouple, grounded or ungrounded sensors
- RTD 2- or 3-wire, platinum, 100Ω @ 0°C calibration to DIN curve ($0.00385\Omega/\Omega/^\circ\text{C}$) or JIS curve ($0.003916\Omega/\Omega/^\circ\text{C}$); user selectable
- Process, 4-20mA @ 5Ω, or 0-5V_{dc} @ 10kΩ input impedance
- Sensor break protection de-energizes control output to protect system or selectable bumpless transfer to manual operation
- °F or °C or process units display, user selectable

Input Range

Specified temperature ranges represent the controller's operational span.

• Thermocouple

Type J	32 to 1382°F	or	0 to 750°C
Type K	-328 to 2282°F	or	-200 to 1250°C
Type N	32 to 2282°F	or	0 to 1250°C
Type S	32 to 2642°F	or	0 to 1450°C
Type T	-328 to 662°F	or	-200 to 350°C

• RTD Resolution (DIN or JIS)

1°	-328 to 1292°F	or	-200 to 700°C
0.1°	-199.9 to 999.9°F	or	-128.8 to 537.7°C

• Process

4-20mA @ 5Ω	or	-999 to 9999 units
0-5V (dc) @ 10kΩ	or	-999 to 9999 units

Output 1 (Heating or Cooling)

- Electromechanical relay¹. Form C, rated at 8A @ 125V~ (ac) or 5A @ 240V~ (ac) or 5A @ 30V_{dc} (dc), max. at resistive load, without contact suppression. Max. switching current is 10A, max. switching power is 2500VA, and max. switching voltage is 277V~ (ac) or 110V_{dc} (dc).
- Switched dc signal provides a non-isolated minimum turn on voltage of 3V_{dc} (dc) into a minimum 500Ω

load; maximum on voltage not greater than 12V_{dc} (dc) into an infinite load.

- 4-20mA reverse or direct acting, non-isolated 0 to 800Ω load.
- Solid-state relay³, Form A, 0.5A @ 24V~ (ac) min., 264V~ (ac) max., opto-isolated burst fire switched, without contact suppression. Off-state output impedance is 31MΩ.

Output 2 (Heat, Cool or Alarm)

- Electromechanical relay¹. Form C, rated at 8A @ 125V~ (ac) or 5A @ 240V~ (ac) or 5A @ 30V_{dc} (dc), max. at resistive load, without contact suppression. Max. switching current is 10A, max. switching power is 2500VA, and max. switching voltage is 277V~ (ac) or 110V_{dc} (dc).
- Switched dc signal provides a non-isolated minimum turn on voltage of 3V_{dc} (dc) into a minimum 500Ω load; maximum on voltage not greater than 12V_{dc} (dc) into an infinite load.
- Solid-state relay³, Form A, 0.5A @ 24V~ (ac) min., 264V~ (ac) max., opto-isolated burst fire switched, without contact suppression. Off-state output impedance is 31MΩ.
- Alarm output can be latching or non-latching, and process or deviation with separate high and low values. Alarm silencing (inhibit) on power up (for deviation alarms only).

Output Configurations

• Output 1

User selectable as: on/off: P, PI, PD, PID, heat or cool action

- Adjustable switching differential: 1 to 99°F (1 to 55°C)
- Proportional band: 0 (off) or 1 to 999°F (0 to 555°C) or 0.0 to 999.9 units

Integral: 0 (off) or 0.1 to 99.9 minutes per repeat

Reset: 0 (off) or 0.01 to 9.99 repeats per minute

Rate/derivative: 0 (off) or 0.01 to 9.99 minutes

Cycle time: 0.1 to 999.9 seconds

• Output 2

User selectable as: Control with action opposite that of Output 1 (heating or cooling)

- Process or deviation alarm with flashing alarm message
- Process or deviation alarm without alarm message
- Alarm with separate high and low set points
- Hysteresis: 1 to 9999° or units switching differential

Line Voltage/Power

- 100-240V~ (ac), -15%, +10%; (85-264V~ [ac]) 50/60Hz, $\pm 5\%$
- 14-24V_{dc} (ac/dc), +10%, -15%; (12-26V_{dc} [ac/dc]) 50/60Hz, $\pm 5\%$
- Fused internally (factory replaceable only) Slo-Blo® type (time-lag):
 - 1A, 250V for high voltage versions
 - 2A, 250V for low voltage versions
- Maximum power consumption: 12VA (100 to 240V~ [ac]), 7VA (12 to 24V_{dc} [ac/dc])
- Data retention upon power failure via non-volatile memory

Operating Environment

- 32 to 149°F (0 to 65°C)
- 0 to 90% RH, non-condensing

Storage Temperature

- -40° to 185°F (-40° to 85°C)

Terminals

- Touch-safe, plugable terminal blocks
- 22 to 12 AWG

Controller Weight

- 0.68 lb (310g)

Shipping Weight

- 0.75 lb(0.34 kg)

Dimensions

- 1/4 DIN size and NEMA 4X² front panel make the Series V4 easy to apply and maintain in a wide variety of applications. Unique mounting brackets, gasket and collar make installation a snap.

Overall Height: 4.3 inches (109 mm)

Width: 4.3 inches (109 mm)

Depth: 4.0 inches (101 mm)

Depth Behind Panel Surface:

3.875 inches (98.4 mm)

Agency Approvals

- UL, C-UL, CE, NEMA 4X
- CE 89/336/EEC (EN 50082-2, EN 50081-2)
- CE 73/23/EEC (EN61010-1, EN 60730-1 and EN 60730-2-9)

- 1 Electromechanical relays warranted for 100,000 closures only. Solid-state switching devices recommended for applications requiring fast cycle times or extended service life.
- 2 To effect NEMA 4X rating requires a minimum mounting panel thickness of 0.06inch (1.5 mm) and surface finish not rougher than 0.000032 inch (0.000812 mm).
- 3 Switching inductive loads (relay coils, etc.) requires using an RC suppressor.

Note: These specifications are subject to change without prior notice.

Ordering Information

(1466)

Series V4

Temperature controller, single analog input, single control output, dual 4-digit displays

Power Supply

H = 100-240V~(ac)

L = 14-24V≈(ac/dc)

Output 1

C = Switched dc output, non-isolated

D = Electromechanical relay, Form C, max. switching current 10A (refer to specifications), without contact suppression^{1,3}

F = Process, 4-20mA≈(dc), non-isolated

K = Solid state relay, Form A, 0.5A, without contact suppression³

Output 2

A = None

C = Switched dc output, non-isolated

D = Electromechanical relay, Form C, max. switching current 10A (refer to specifications), without contact suppression^{1,3}

K = Solid state relay, Form A, 0.5A, without contact suppression³

Display Options

Upper/Lower

RR = Red/Red display

RG = Red/Green display

GR = Green/Red display

GG = Green/Green display

XX = Custom Overlays

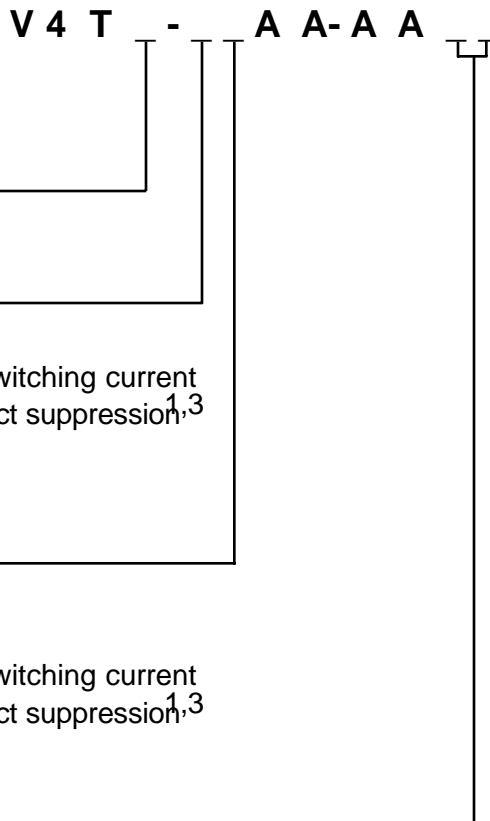

Series V4 Software Map

Setup Menu

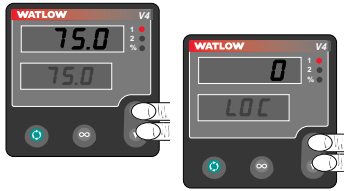

Enter the Setup Menu by pressing the **Up-arrow** and **Down-arrow** keys simultaneously for three seconds. The lower display shows the **LOC** Lock parameter, and the upper display shows its current level. All keys are inactive until you release both keys. You can reach the Lock parameter from anywhere. Use the **Advance** key to move through the menus and the **Up-arrow** and **Down-arrow** keys to select data. You will not see all parameters in this menu, depending on the controller's configuration and model number.

Setup Menu

- LOC** Lock
- in** Input
- dEC** Decimal*
- C-F** Celsius - Fahrenheit*
- rL** Range Low
- rH** Range High
- DE1** Output 1
- HSC** Hysteresis Control
- DE2** Output 2
- HSA** Hysteresis Alarm*
- LAE** Latching*
- STL** Silencing*
- rtd** RTD*
- rP** Ramping
- rt** Rate*
- PL** Power Limiting*
- dSP** Display

* Parameter may not always appear.

Note:

Do not enter any values here; make photocopies instead.

Operation Menu

- 4000** Control Set Point
- Pb1** Proportional Band 1
- rE1** Reset 1*
- IE1** Integral 1*
- rA1** Rate 1*
- dE1** Derivative 1*
- CE1** Cycle Time 1*
- ALD** Alarm Low*
- AHI** Alarm High*
- Pb2** Proportional Band 2*
- rE2** Reset 2*
- IE2** Integral 2*
- rA2** Rate 2*
- dE2** Derivative 2*
- CE2** Cycle Time 2*
- CAL** Calibration Offset
- AUE** Auto-Tune

* Parameter may not always appear.

Parameter	Value	Range	Factory Default	Appears If:
LOC		0 , 1 , 2 , 3 , 4 **	0	DIP switch selectable.
in		U , H , E , n , S , rtd , rtd , 0-5 , 420	U	
dEC		0, 0.0, 0.00	0	in is set to 0-5 or 420
C-F		C or F	Dependent on dFL H , E , n .	in is set to U , S , rtd , or rted
rL		rL to rH	Input dependent.	
rH		rH to rL	Input dependent.	
DE1		HE or CL	HE	
HSC		1 - 99, 0.1 - 9.9, 0.01 - 0.99°F 1 to 55, 0.1 to 5.5, 0.01 to 0.55°C	3, 0.3, 0.03°F 2, 0.2, 0.02°C	
DE2		Con = Control PrA = Process Alarm Pr = Process with no alarm message dEA = Deviation alarm dE = Deviation with no alarm message no = None	Con	
HSA		1 - 9999, 0.1 - 999.9, 0.01 - 99.99°F 1 - 5555, 0.1 - 555.5, 0.01 - 55.55°C	3, 0.3, 0.03°F 2, 0.2, 0.02°C	DE2 is not set to Con or no
LAE		LAE or nLA	nLA or no	DE2 is not set to Con
STL		On or OFF	OFF dE	DE2 is set to dEA or dE
rtd		UIS or din	din rted	in is set to rted or rted
rP		SEr is set to Ramping on power up on is set to Ramping to set point always OFF is set to None	OFF	
rt		0 to 9999	100°/hr	rP is not set to OFF
PL		0 to 100	100	
dSP		nor = normal SE = Set Point (lower only) Pro = Process (upper only)	nor	

**LOC Functions

- 0**: All operating parameters may be viewed or changed. Manual operation is permitted. Bumpless transfer to manual mode will occur on sensor break.
- 1**: The set point, actual, and alarm settings are only visible parameters, set point is adjustable in this level. Manual operation and auto-tune are permitted. Bumpless transfer to manual mode will occur on sensor break.
- 2**: The set point, actual, and alarm settings are the only visible parameters, set point is adjustable in this level. Manual operation is permitted. Bumpless transfer to manual mode will occur on sensor break.
- 3**: The set point and actual are the only visible parameters, set point is adjustable in this level. Manual operation is not permitted. Bumpless transfer is defeated and outputs are disabled on sensor break.
- 4**: The set point and actual are the only visible parameters, set point is not adjustable in this level. Manual operation is not permitted. Bumpless transfer is defeated and outputs are disabled on sensor break.

Operation Menu

Parameter	Value	Range	Factory Default
Pb1		If dFL is set to US : 0 - 999°F/0 - 555°C/0 - 999 Units 0 - 99.9°F/0 - 55.5°C/0 - 99.9 Units 0 is set to ON/OFF control. HSC is set to switch diff. If dFL is set to SI : 0.0 to 999.9% of span	25°F 2.5°F 3%
rE1		0.00 to 9.99 repeats/minute 0.00 = No Reset. Won't appear if Pb1 is set to 0 or dFL is set to SI .	0.00 repeats/minute
IE1		0.0 - 99.9 minutes/rpt. 0.00 = No Integral. Won't appear if Pb1 is set to 0 or dFL is set to US .	00.0 minutes/repeat
rA1		0.00 to 9.99 minutes 0.00 = No Rate. Will not appear if Pb1 is set to 0 or dFL is set to SI .	0.00 minutes
dE1		0.00 - 9.99 minutes. 0.00 = No Derivative. Won't appear if Pb1 is set to 0 or dFL is set to US .	0.00 minutes
CE1		0.1 to 999.9 Won't appear if Pb1 = 0, or 420 .	5.0 seconds
Pb2		Same as Pb1 . Pb2 lower limit = 1, 0.1, 0.01	
rE2		Same range as rE1 .	
IE2		Same range as IE1 .	
rA2		Same range as rA1 .	
dE2		Same range as dE1 .	
CE2		Same range as CE1 .	
ALD		Deviation dE -999 to 0 Process Pr rL to AHI Will not appear if DE2 is set to no or Con .	rL
AHI		Deviation dE 0 to 999 Process Pr ALD to rH Will not appear if DE2 is set to no or Con .	rH
CAL		±180°F/±100°C/±180 Units	0
AUE		0-3	0